



Self-Contained Emergency Luminaire PTH-311 (1.0W Power LED)



PTH-311



Specifications

- Model..... ➔ PTH-311.
- Mode..... ➔ Non-maintained.
- Weight..... ➔ 320 grams.
- Battery..... ➔ 2.4V 1.7AH Ni-cad.
- Housing..... ➔ Injection moulded fire retardant, UV stabilize ABS Housing.
- Charger..... ➔ Constant Current.
- Mounting..... ➔ Recess mounted on ceiling.
- Dimension..... ➔ 75 mm (L) x 88 mm (W) x 95 mm (Diameter).
- Monitoring..... ➔ Green / Red LED “ ON ” to indicate charging.
Equipped with push test switch to simulate power failure.
- Compliance..... ➔ SIRIM MS 619-2-22:2005. MS IEC 60598-1:2012.
Jabatan Bomba dan Penyelamat Malaysia certified.
- Light Source..... ➔ 1.0W high lumen output LED.
- Input Voltage..... ➔ 240V +/- 10% 50Hz.
- Recharge Period..... ➔ 16 - 24 Hours.
- Back Up Duration..... ➔ 3 Hours.
- Battery Protection..... ➔ Low voltage cut-off to prevent over discharging.
- Power Consumption..... ➔ < 5W.
- Ingress of Protection..... ➔ IP - 20.
- Operating Temperature..... ➔ 0°C to 65°C.
- Lumen Per Lamp..... ➔ 84.40 lm

For further enquiries, please contact :-
PNE SYSTEMS SDN. BHD. (263861 D)
 No.3, Jalan SS26/13, Taman Mayang Jaya
 47301, Petaling Jaya, Selangor Darul Ehsan.
 Tel : (6)03-78037488 (Hunting)
 Fax : (6)03-78038509
 E-mail : sales@pnesys.com.my
 Website : www.pnesys.com.my

MODEL PTH-311

Self-Contained Emergency Luminaire

1.0W Power LED

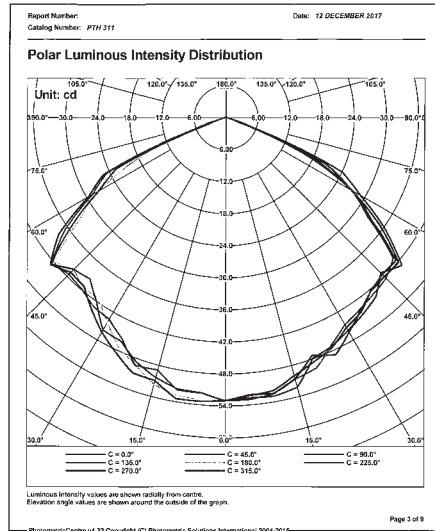

SRM QAS International Sdn Bhd
 No. 1, Persiaran Darul Muzaffar, P.O. BOX 7885, Section 2
 47101, Shah Alam, Selangor Darul Ehsan, Malaysia
 Tel: +603 5546 8281
 Fax: +603 5546 8272
 www.srm-qas.com.my

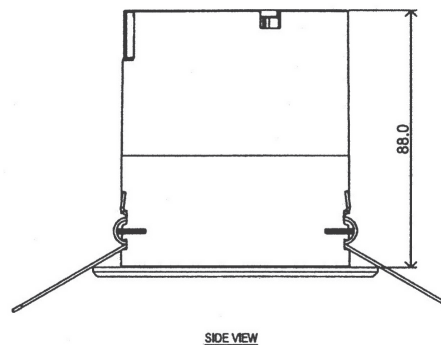
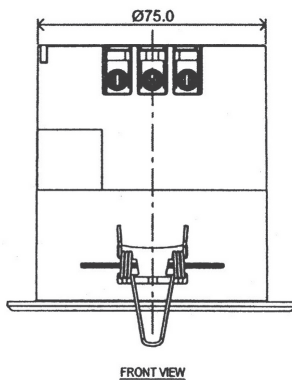
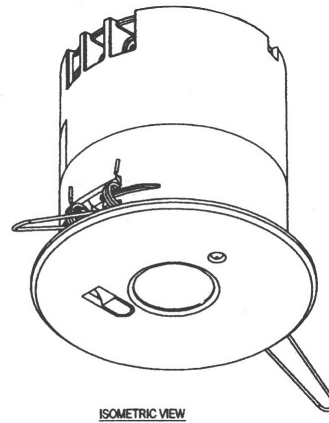
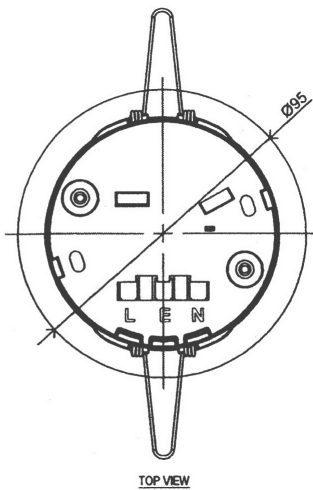

For further enquiries, please contact :
PNE SYSTEMS SDN. BHD. (263861 D)
 No. 3, Jalan SS 26/13,
 Taman Mayang Jaya, 47301 Petaling Jaya,
 Selangor Darul Ehsan, Malaysia.
 Tel : 03-7803 7488 (Hunting)
 Fax: 03-7803 8509
 E-mail: sales@pnesys.com.my



Note : Due to continuous development and improvement, our company reserves the right to change specification without notice.